

2.4 NUMERICAL RESULTS AND DISCUSSION

Numerical results are presented by normalizing the frequency variables with respect to ω_o and letting $\omega_o = 1$ and using $\frac{z}{\lambda_o}$ as independent variable where λ_o is the free space wavelength of the source wave. The wiggler fields, in terms of normalized variables are given by:

$$\frac{\vec{h}_w(z)}{H_o} = \hat{y} p \frac{\left(\frac{\omega_p}{\omega_o}\right)^4 \cos\left(2\pi\frac{z}{\lambda_o}\right)}{\left(\frac{\omega_p}{\omega_o}\right)^4 + \left(\frac{\omega_{bw}}{\omega_o}\right)^2 \sin^2\left(2\pi\frac{k_w}{k_o}\frac{z}{\lambda_o} + \phi_w\right) + \left(\frac{\omega_p}{\omega_o}\right)^2} \pm \hat{x} q \frac{\left(\frac{\omega_p}{\omega_o}\right)^2 \sin\left(2\pi\frac{z}{\lambda_o}\right)}{1 + \left(\frac{\omega_p}{\omega_o}\right)^2} \quad (2.27)$$

$$\frac{e_w(z)}{E_o} = p \frac{\left(\frac{\omega_{bw}}{\omega_o}\right)\left(\frac{\omega_p}{\omega_o}\right)^2 \sin\left(2\pi\frac{k_w}{k_o}\frac{z}{\lambda_o} + \phi_w\right) \sin\left(2\pi\frac{z}{\lambda_o}\right)}{\left(\frac{\omega_p}{\omega_o}\right)^4 + \left(\frac{\omega_{bw}}{\omega_o}\right)^2 \sin^2\left(2\pi\frac{k_w}{k_o}\frac{z}{\lambda_o} + \phi_w\right) + \left(\frac{\omega_p}{\omega_o}\right)^2} \quad (2.28)$$

The numerical results are calculated using a left-hand circularly polarized wave by setting $p = 1$ and $q = 1$ in equations (2.1) and (2.3). The numerical results for a right-hand circularly polarized source wave are not shown but can easily be inferred from the results discussed here. In addition, ϕ is set to zero in equation (2.3). The p , q and ϕ terms are shown in the formulation section and solution section to demonstrate the general case.

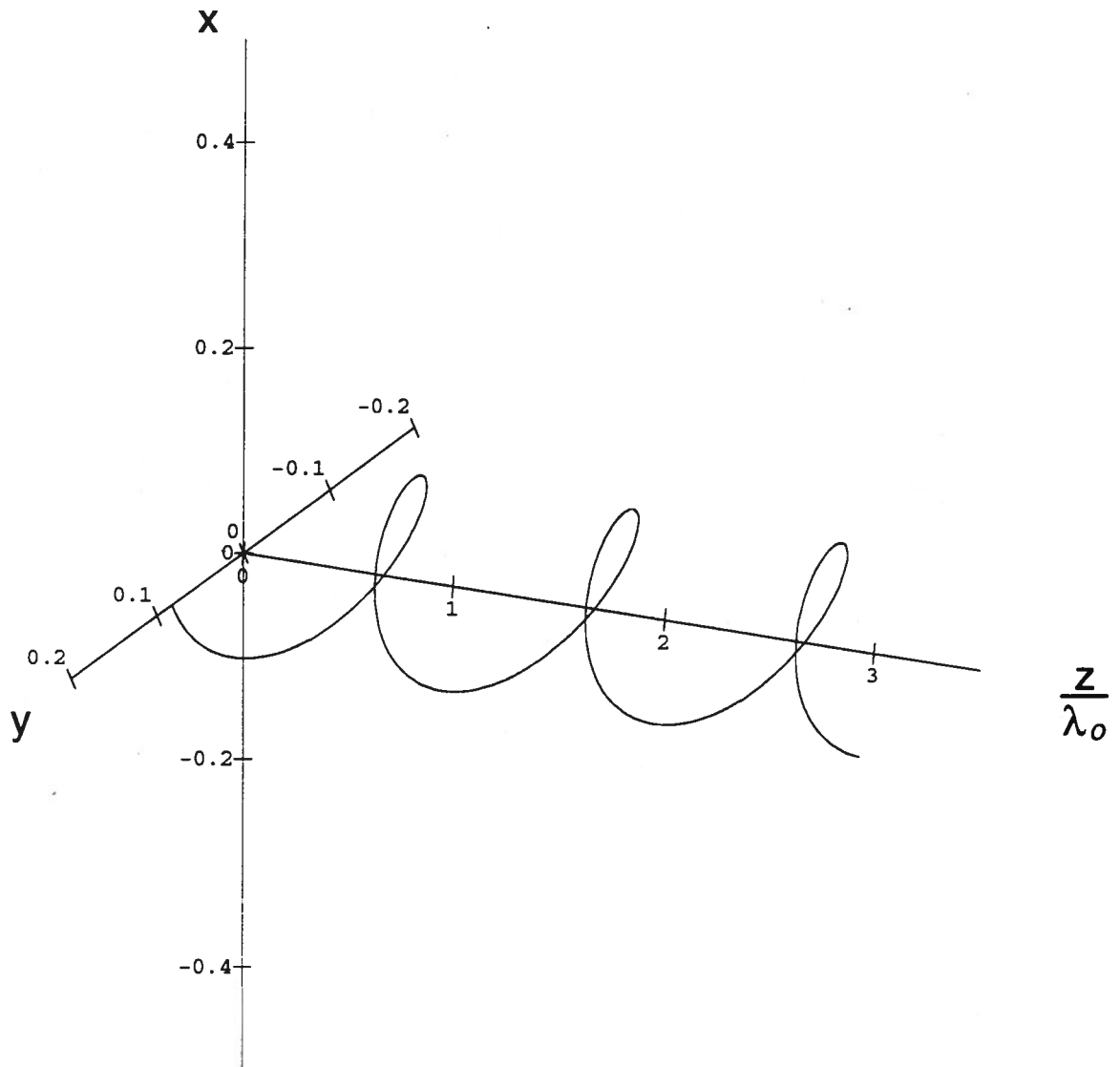

Figure. 2.2 Magnetic wiggler field with $\frac{\omega_{bw}}{\omega_0} = 0$. This results in the x and y components of the magnetic wiggler field having the same magnitude and is referred to as the circularly polarized case.

$\frac{\omega_p}{\omega_0} = 0.3$

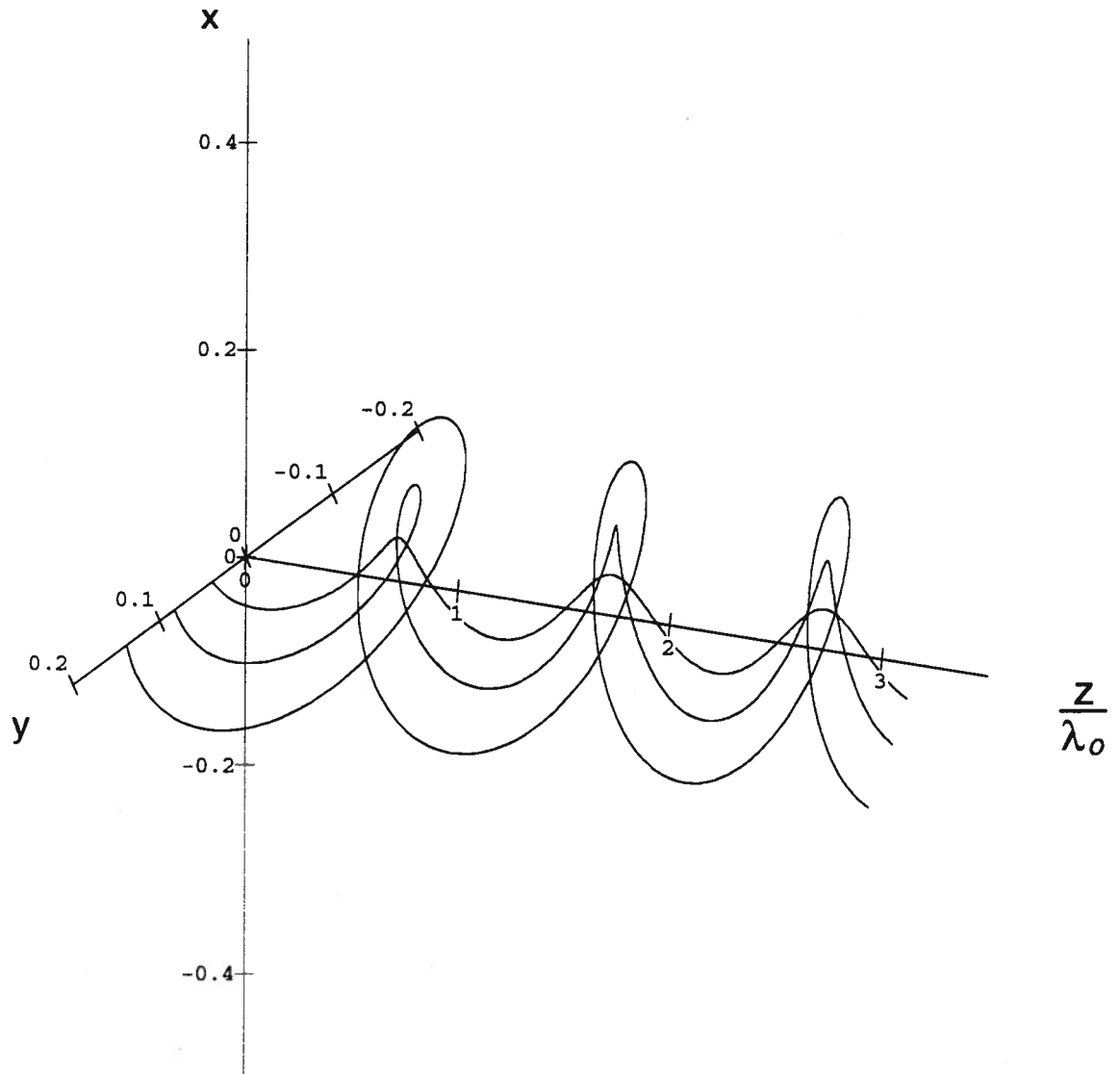

Figure 2.3 Magnetic wiggler field. $\frac{k_w}{k_0} = 0.1$, $\frac{\omega_p}{\omega_0} = 0.2, 0.3, 0.4$, $\frac{\omega_{bw}}{\omega_0} = 0.2$

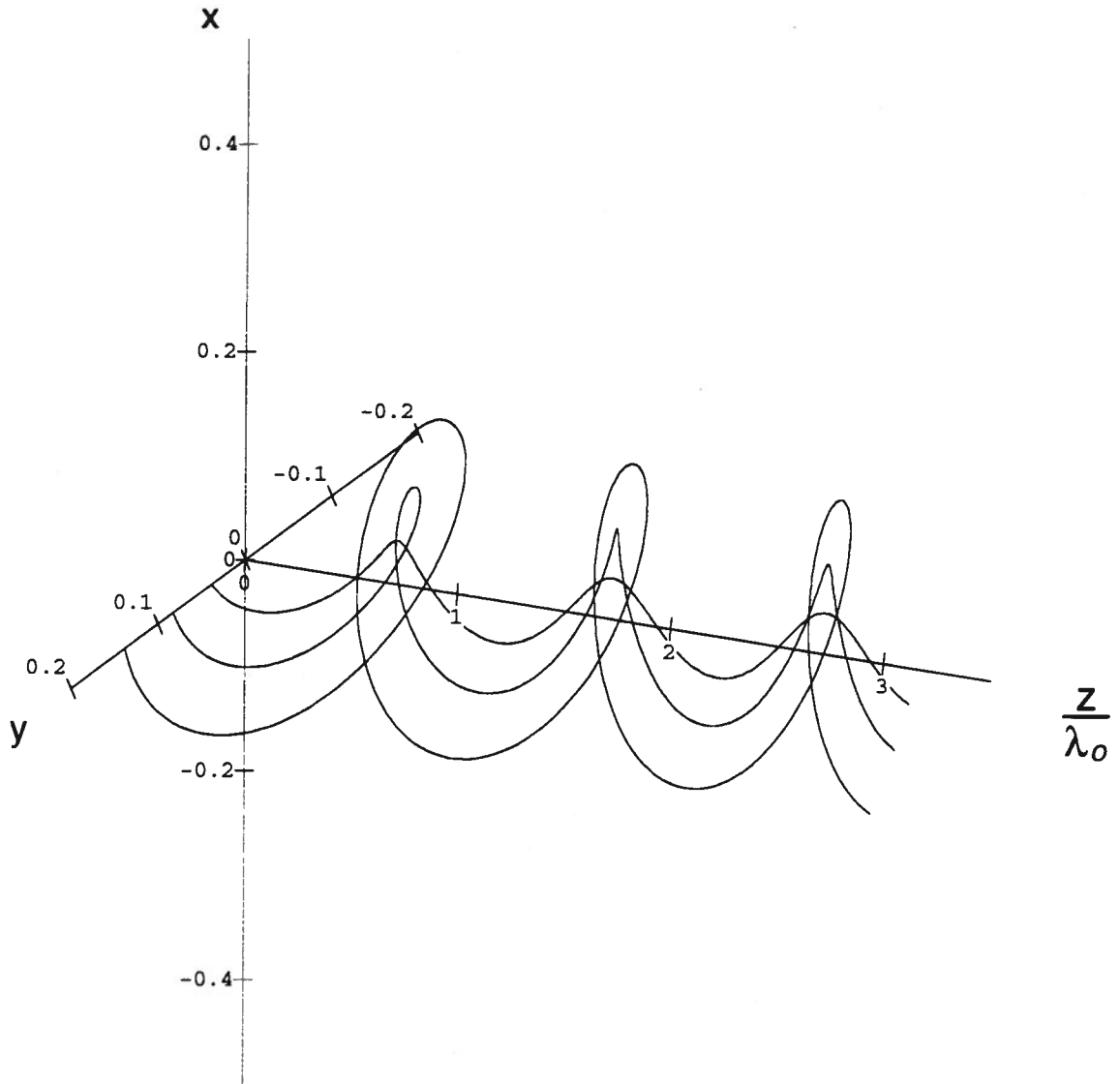

Figure 2.4 Magnetic wiggler field. $\frac{k_w}{k_o} = 0.1$, $\frac{\omega_p}{\omega_o} = 0.2, 0.3, 0.4$, $\frac{\omega_{bw}}{\omega_o} = 0.3$

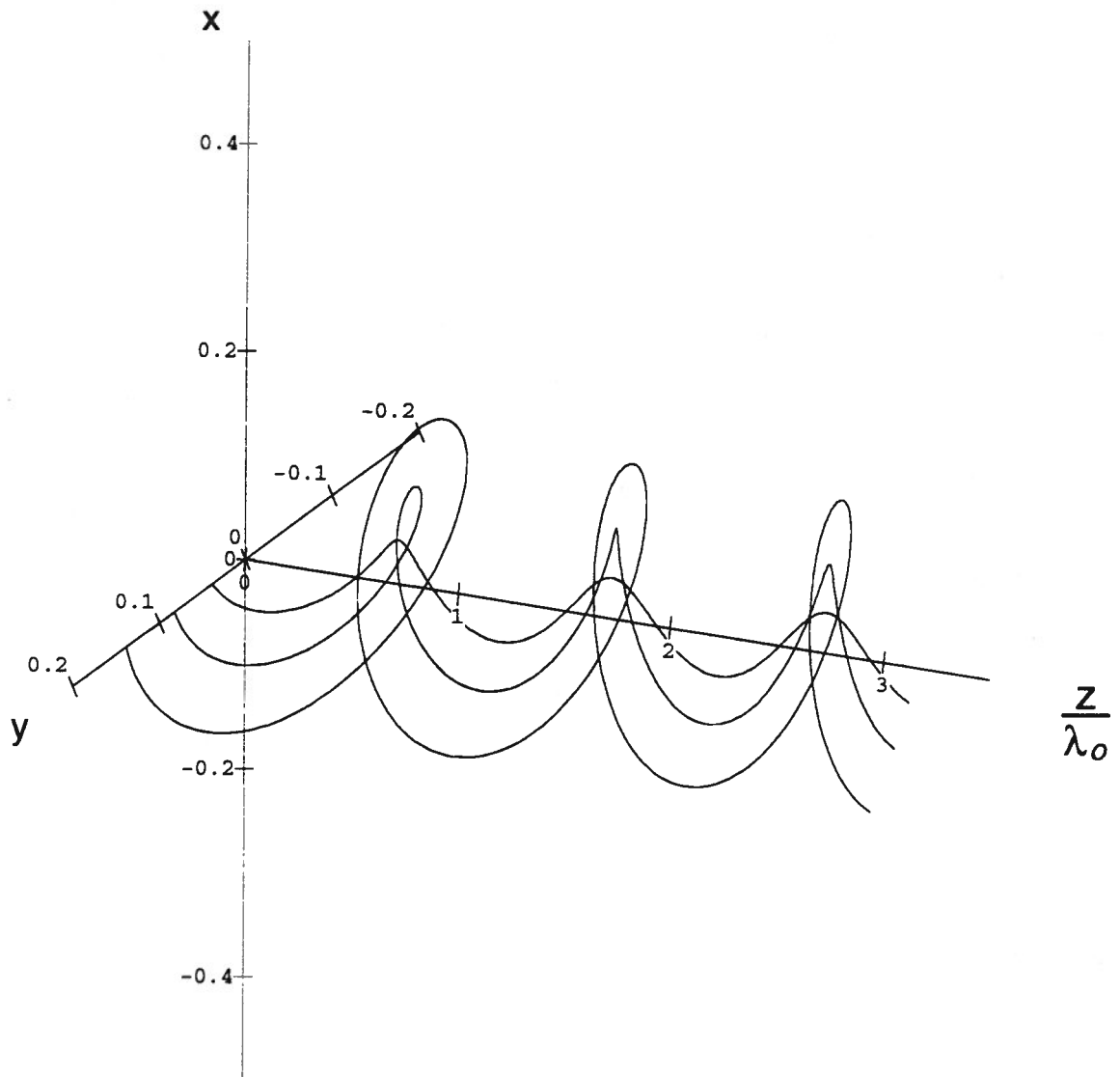

Figure 2.5 Magnetic wiggler field. $\frac{k_w}{k_o} = 0.1$, $\frac{\omega_p}{\omega_o} = 0.2, 0.3, 0.4$, $\frac{\omega_{bw}}{\omega_o} = 0.4$

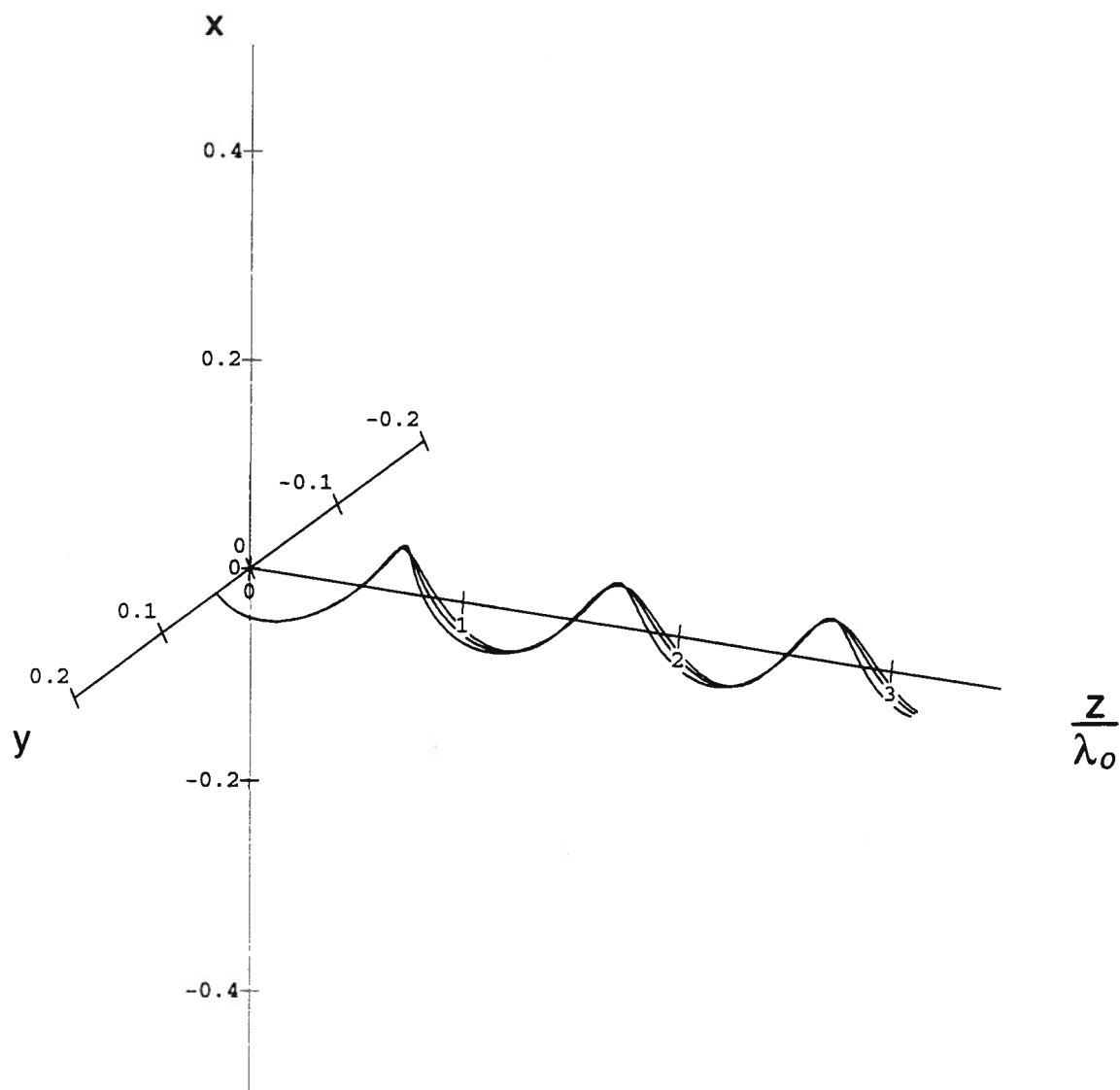

Figure 2.6 Magnetic wiggler field. $\frac{k_w}{k_0} = 0.1$, $\frac{\omega_p}{\omega_0} = 0.2$, $\frac{\omega_{bw}}{\omega_0} = 0.2, 0.3, 0.4$

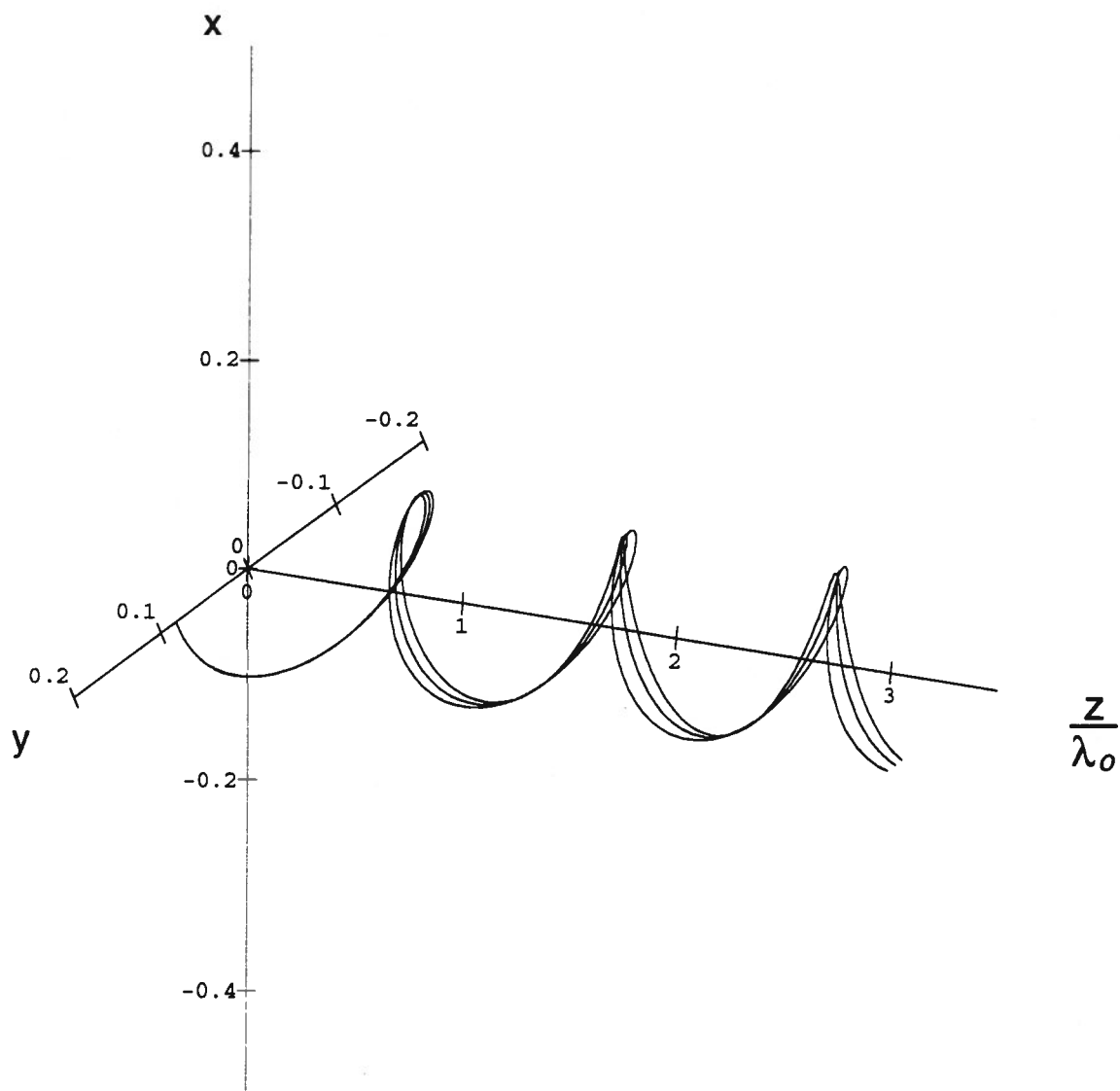

Figure 2.7 Magnetic wiggler field. $\frac{k_w}{k_o} = 0.1$, $\frac{\omega_p}{\omega_o} = 0.3$, $\frac{\omega_{bw}}{\omega_o} = 0.2, 0.3, 0.4$

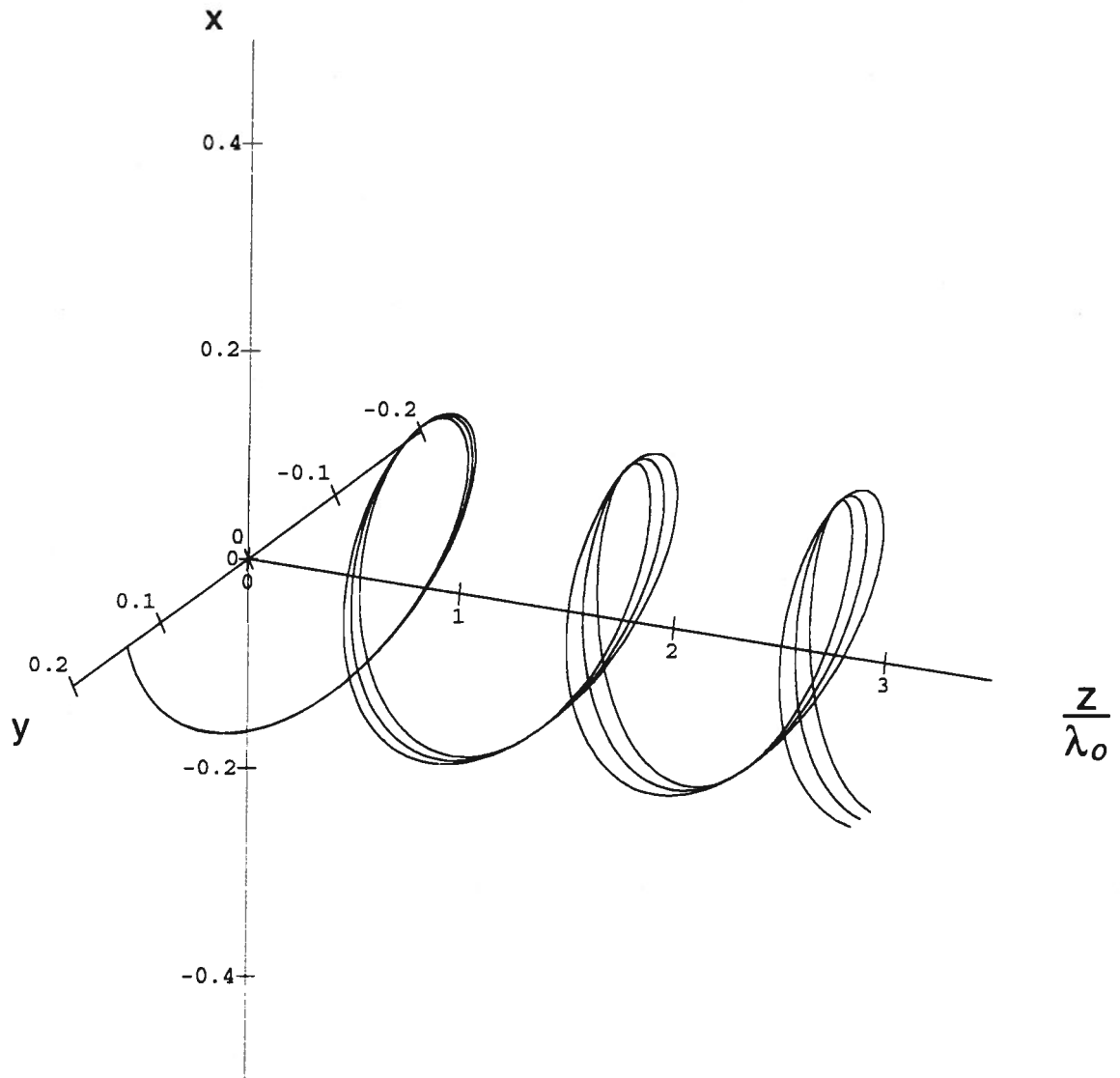

Figure 2.8 Magnetic wiggler field. $\frac{k_w}{k_o} = 0.1$, $\frac{\omega_p}{\omega_o} = 0.4$, $\frac{\omega_{bw}}{\omega_o} = 0.2, 0.3, 0.4$

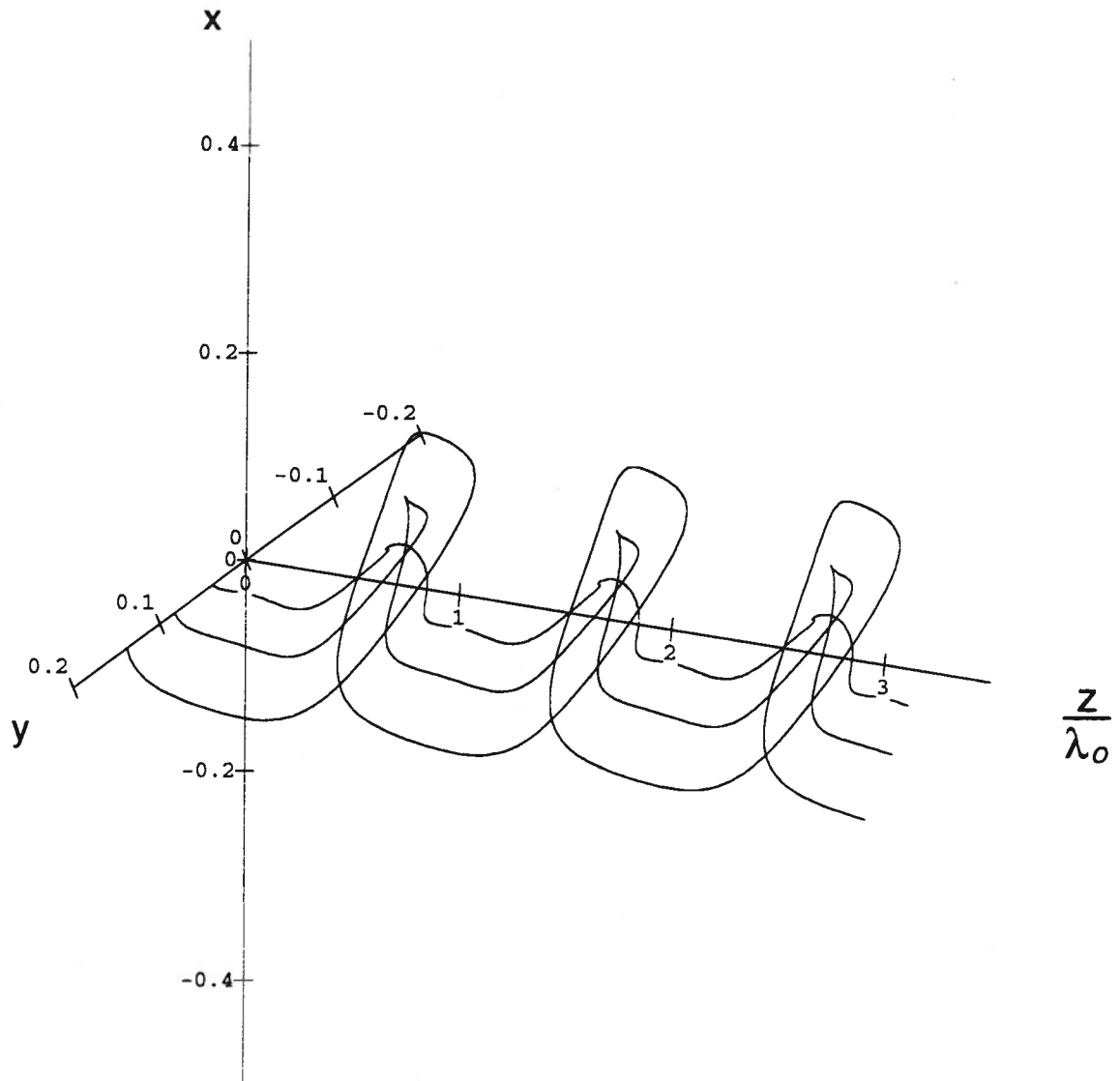

Figure 2.9 Magnetic wiggler field. $\frac{k_w}{k_o} = 1.0$, $\frac{\omega_p}{\omega_o} = 0.2, 0.3, 0.4$, $\frac{\omega_{bw}}{\omega_o} = 0.2$

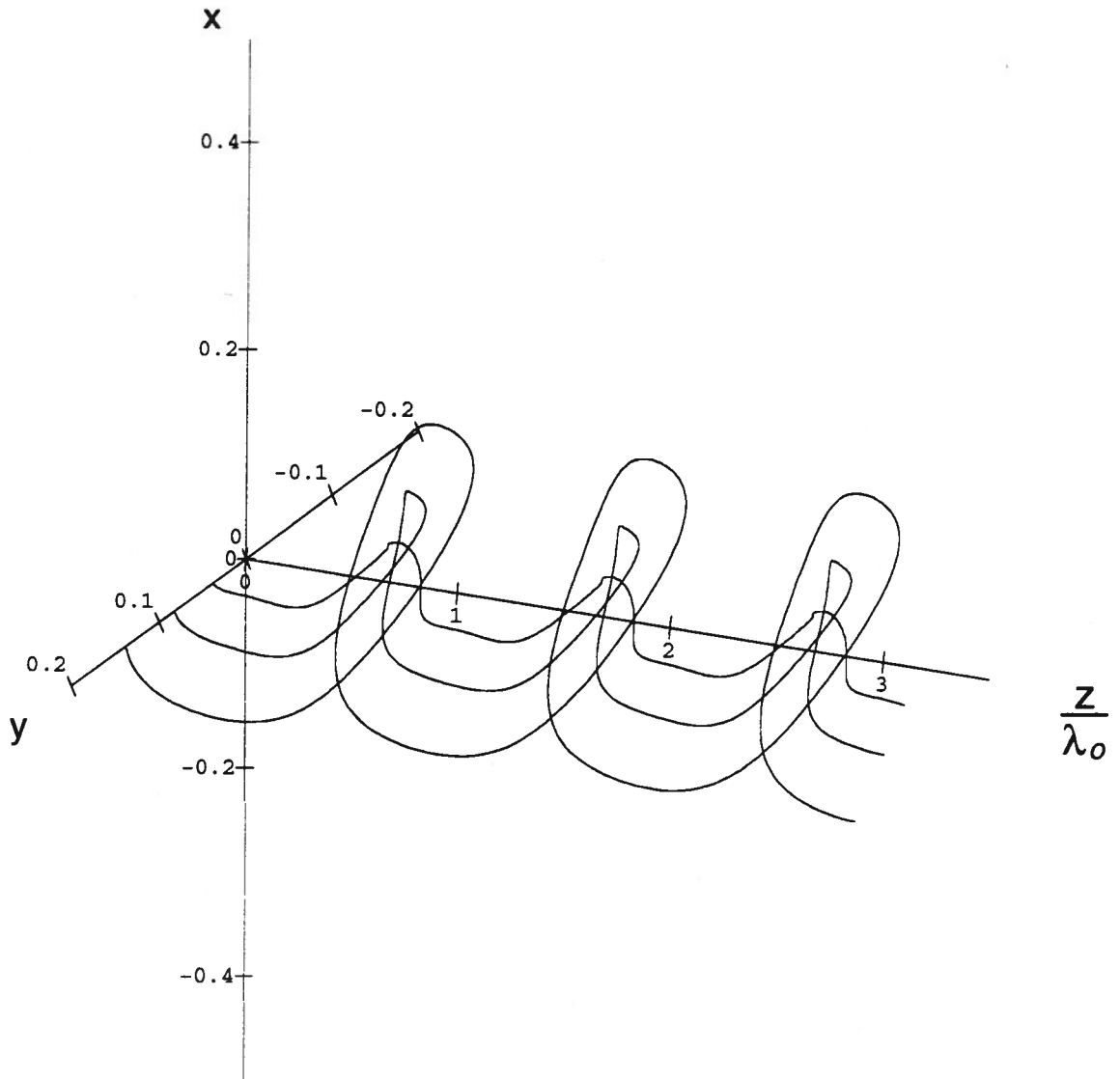

Figure 2.10 Magnetic wiggler field. $\frac{k_w}{k_o} = 1.0$, $\frac{\omega_p}{\omega_o} = 0.2, 0.3, 0.4$, $\frac{\omega_{bw}}{\omega_o} = 0.3$

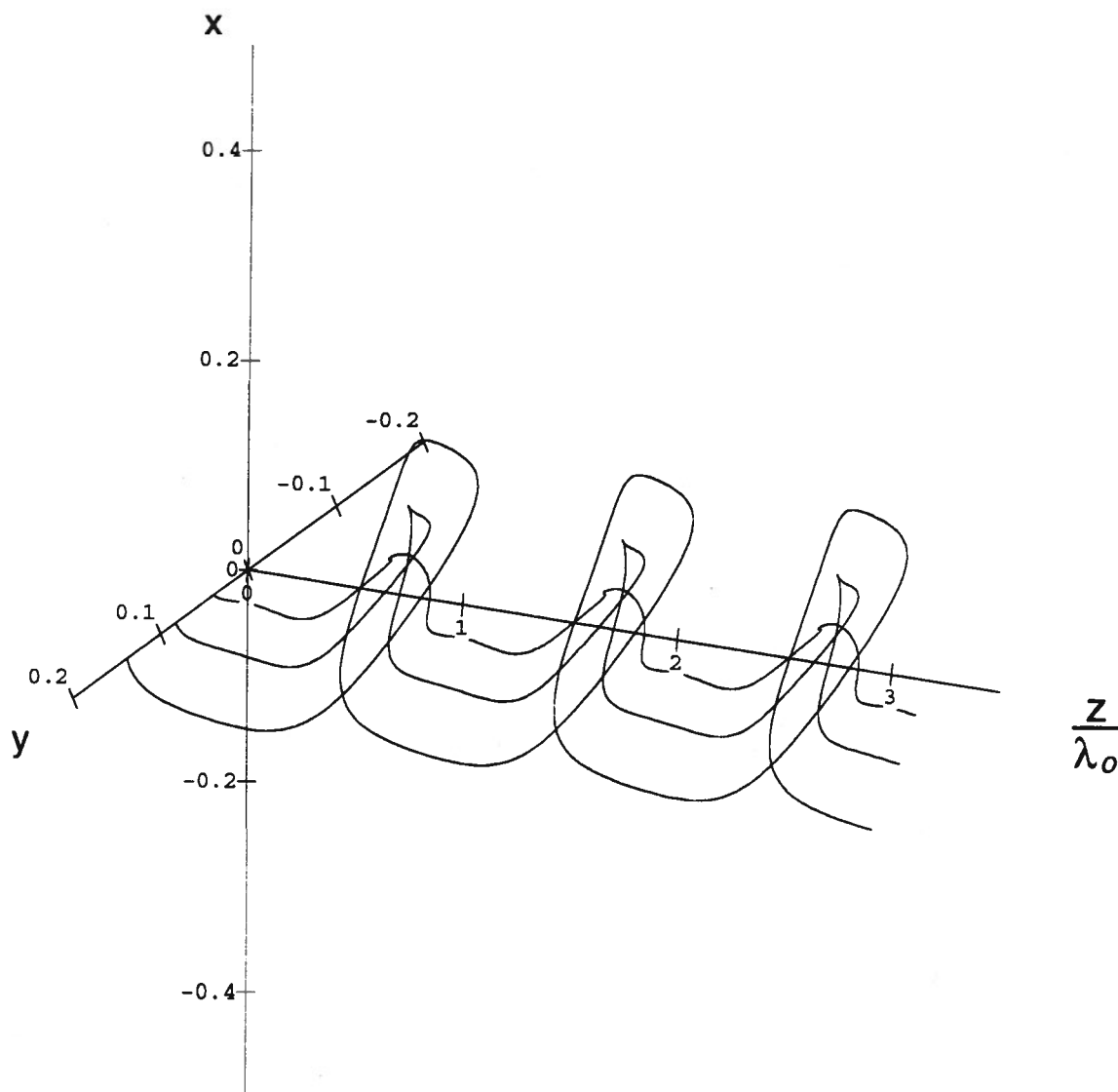

Figure 2.11 Magnetic wiggler field. $\frac{k_w}{k_o} = 1.0$, $\frac{\omega_p}{\omega_o} = 0.2, 0.3, 0.4$, $\frac{\omega_{bw}}{\omega_o} = 0.4$

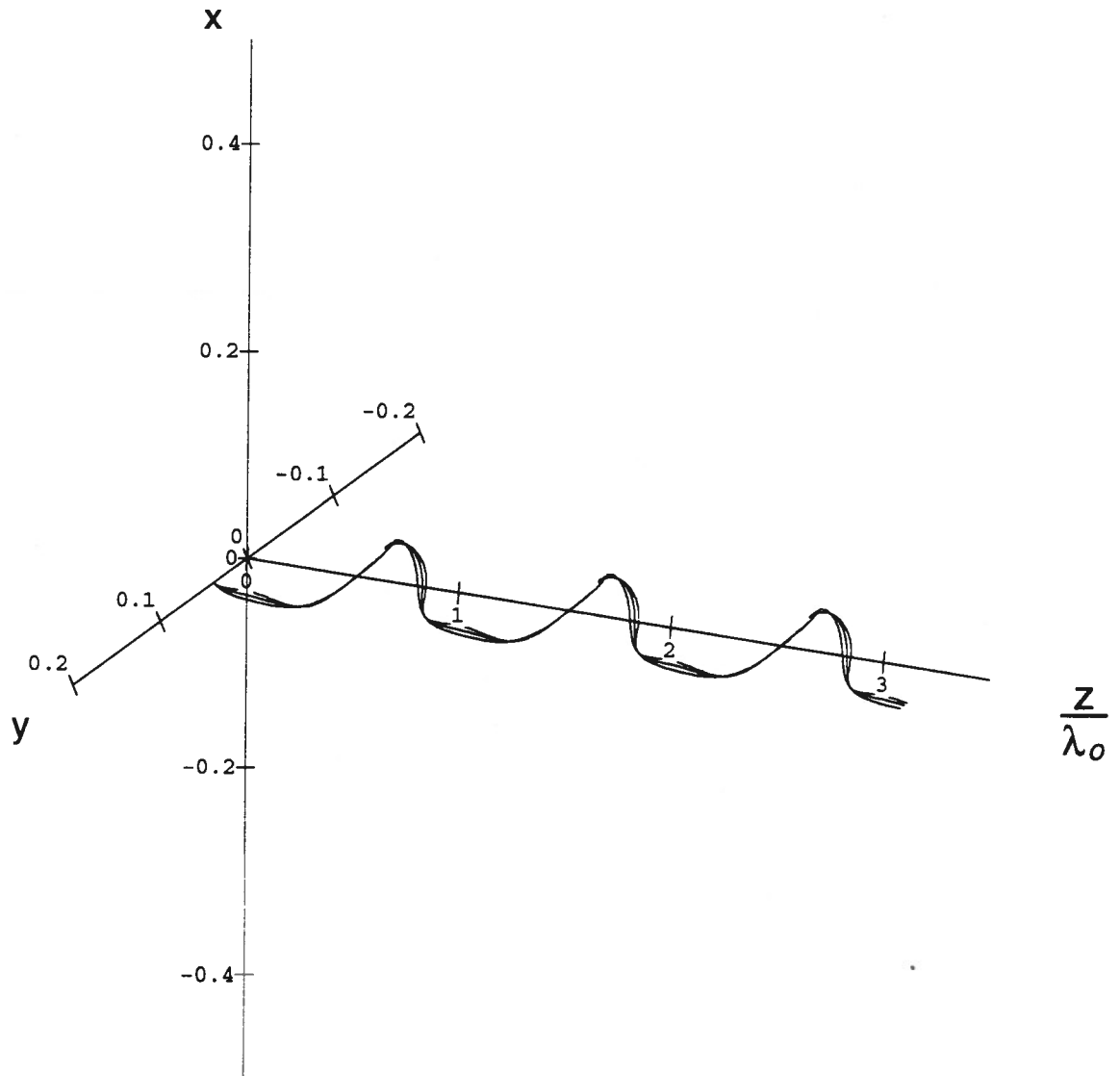

Figure 2.12 Magnetic wiggler field. $\frac{k_w}{k_0} = 1.0$, $\frac{\omega_p}{\omega_0} = 0.2$, $\frac{\omega_{bw}}{\omega_0} = 0.2, 0.3, 0.4$

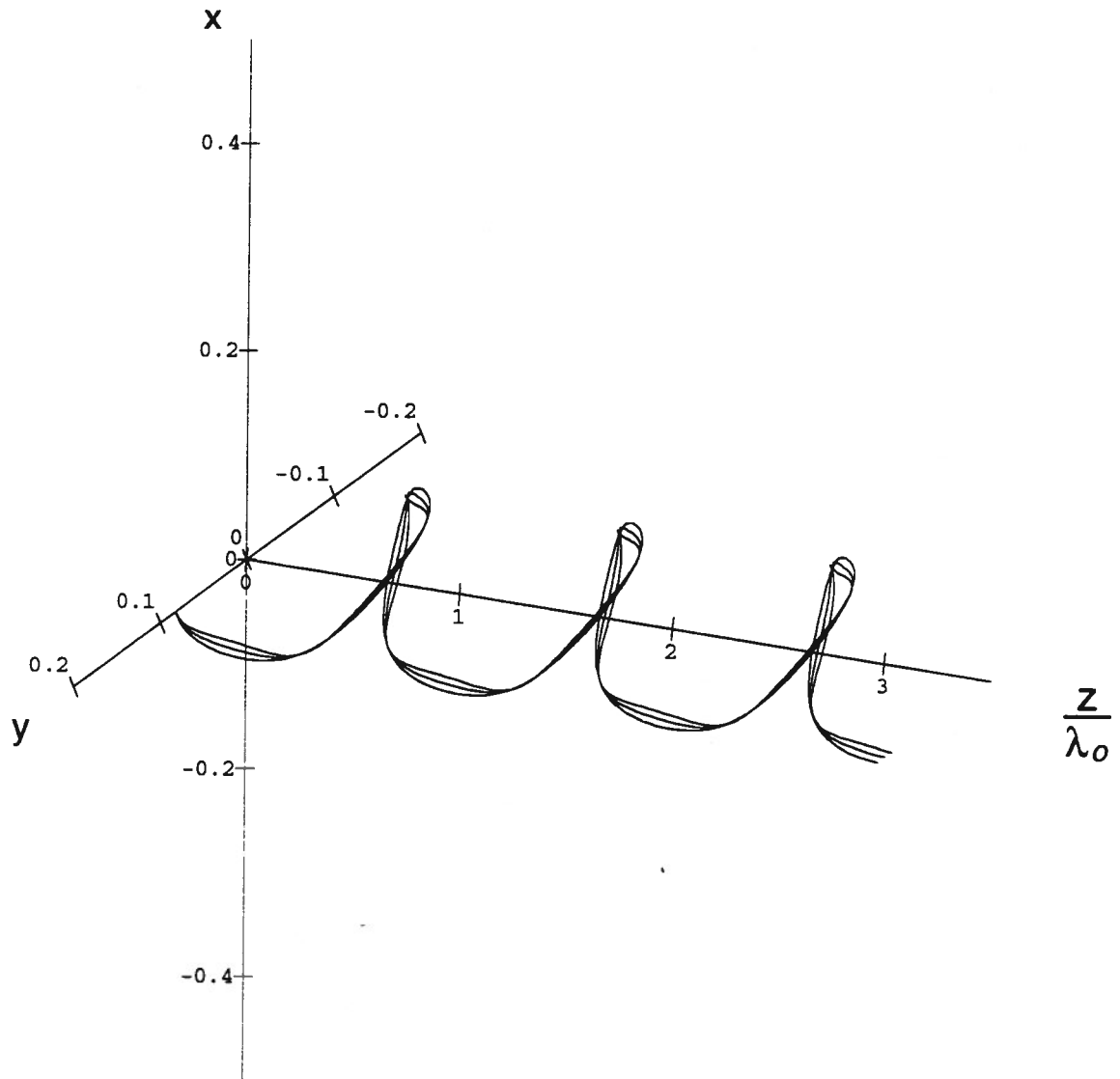

Figure 2.13 Magnetic wiggler field. $\frac{k_w}{k_0} = 1.0$, $\frac{\omega_p}{\omega_0} = 0.3$, $\frac{\omega_{bw}}{\omega_0} = 0.2, 0.3, 0.4$

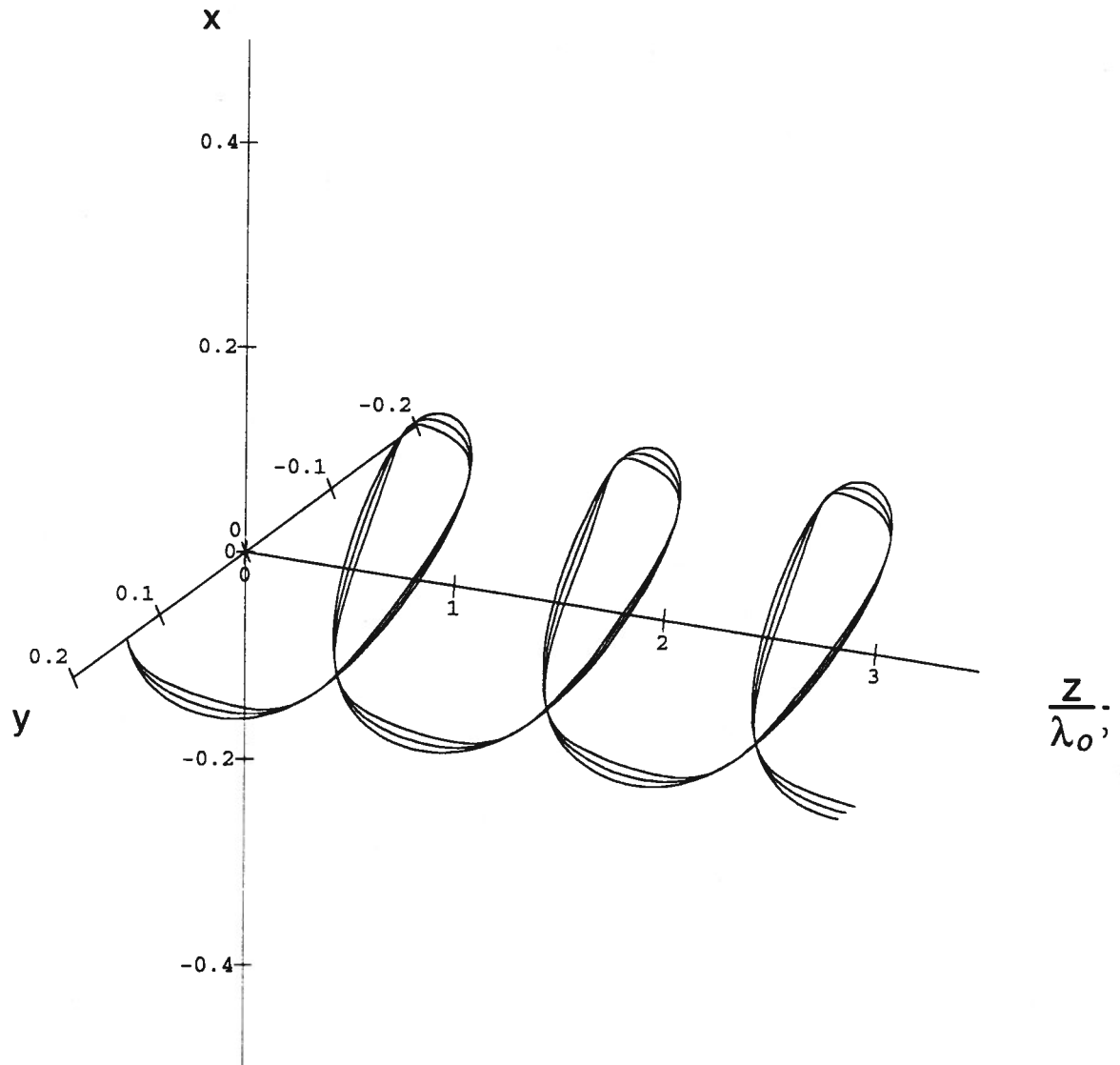

Figure 2.14 Magnetic wiggler field. $\frac{k_w}{k_0} = 1.0$, $\frac{\omega_p}{\omega_0} = 0.4$, $\frac{\omega_{bw}}{\omega_0} = 0.2, 0.3, 0.4$

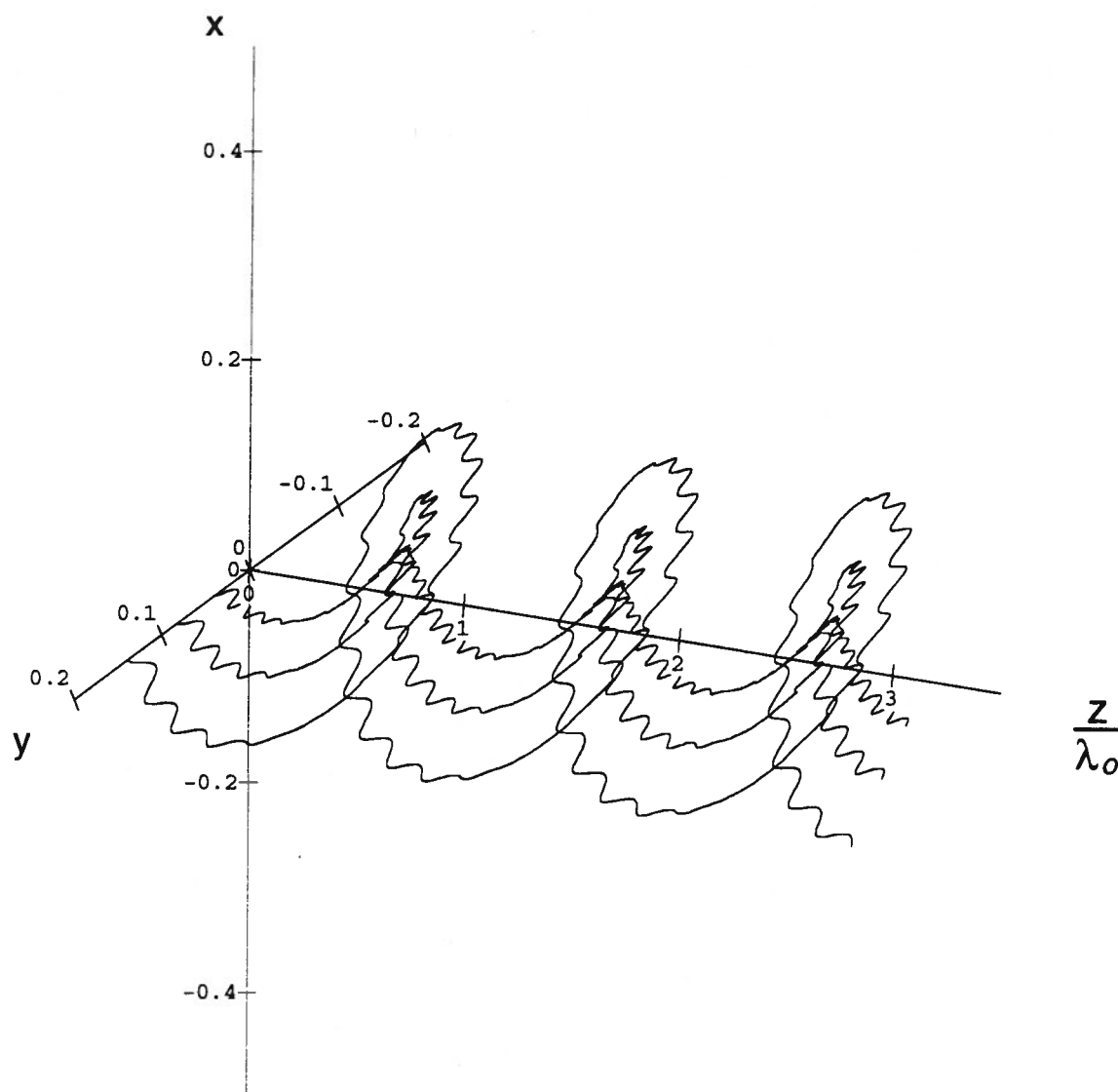

Figure 2.15 Magnetic wiggler field. $\frac{k_w}{k_0} = 10.0$, $\frac{\omega_p}{\omega_0} = 0.2, 0.3, 0.4$, $\frac{\omega_{bw}}{\omega_0} = 0.2$

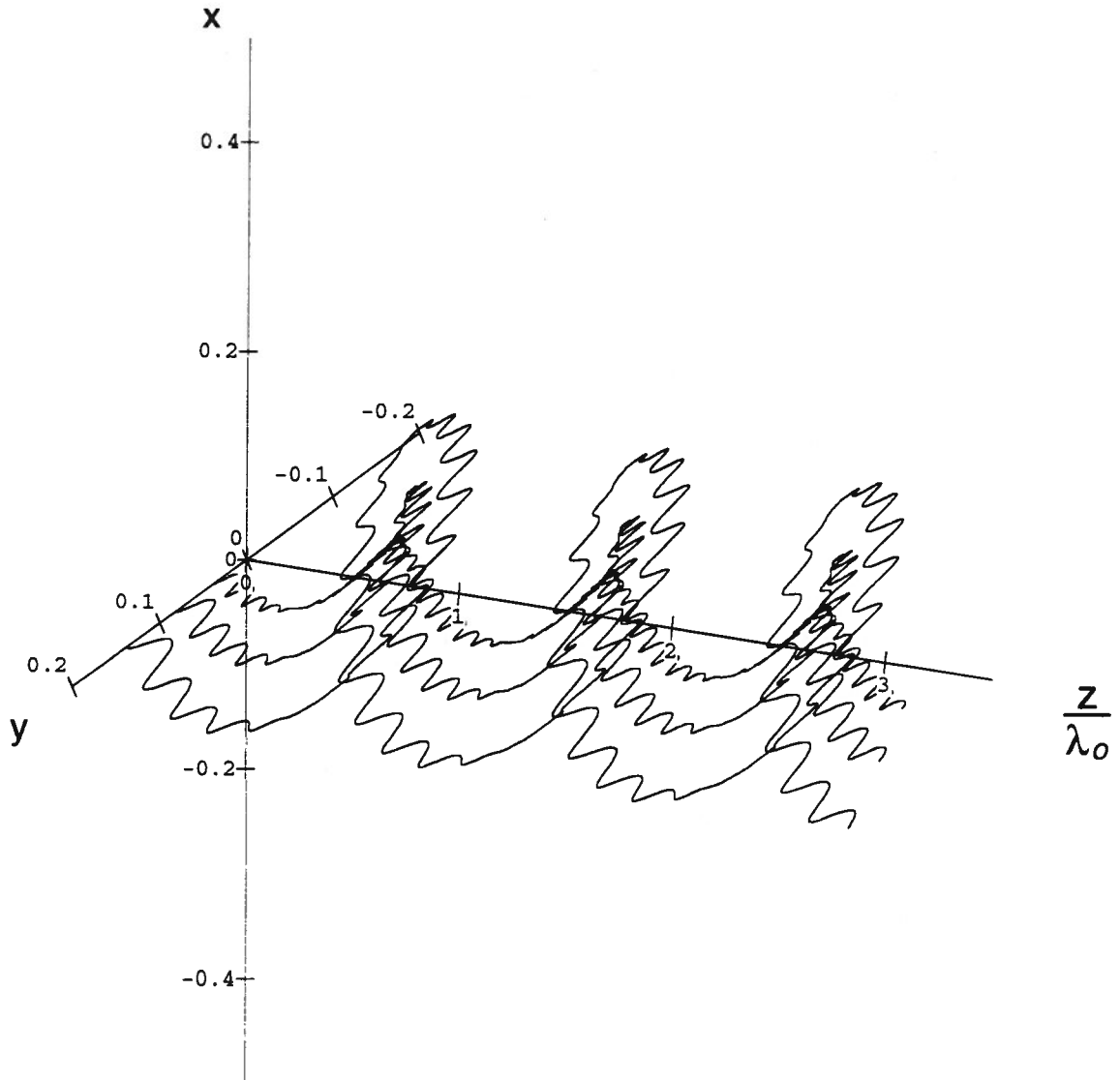

Figure 2.16 Magnetic wiggler field. $\frac{k_w}{k_o} = 10$, $\frac{\omega_p}{\omega_o} = 0.2, 0.3, 0.4$, $\frac{\omega_{bw}}{\omega_o} = 0.3$

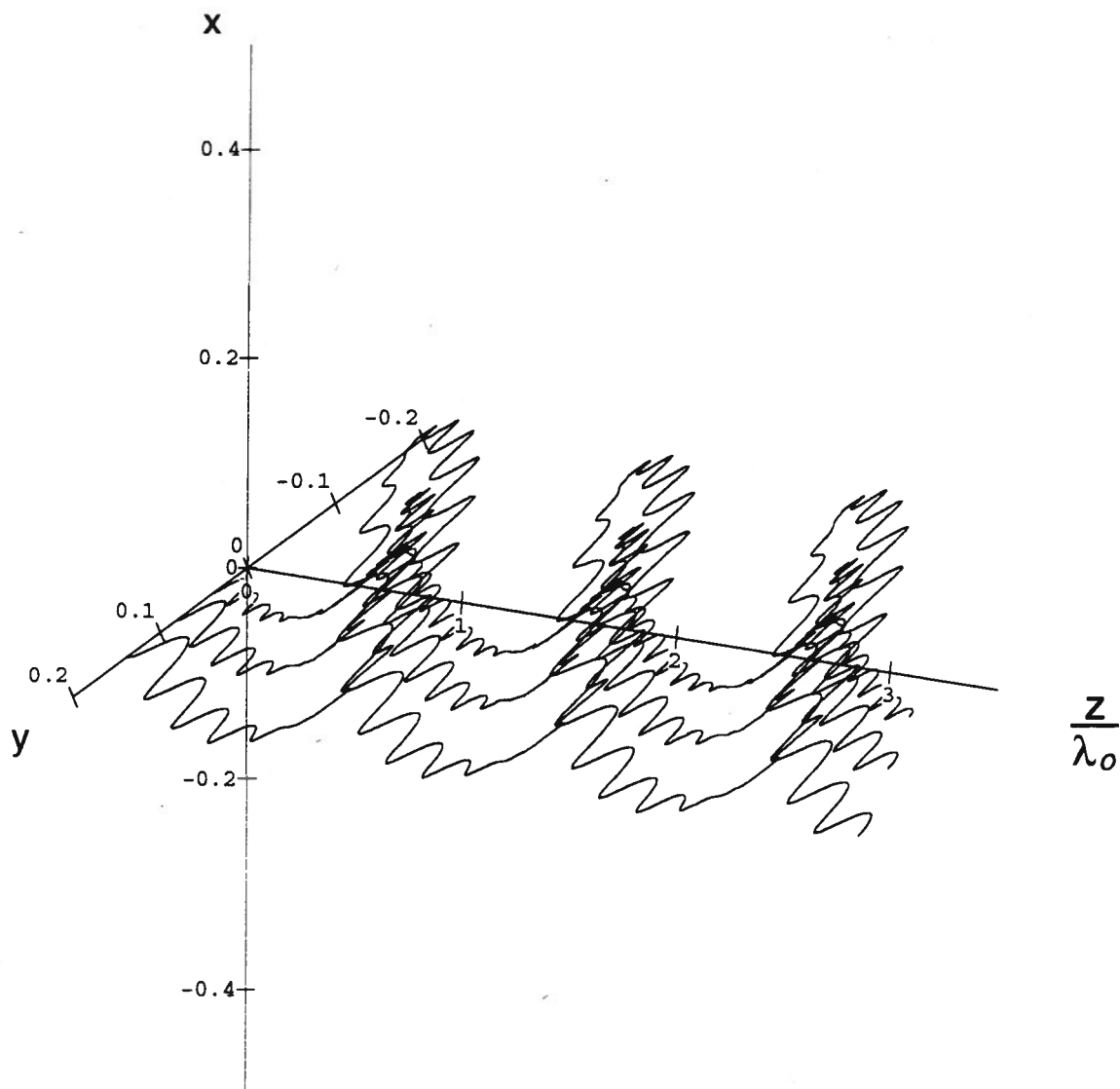

Figure 2.17 Magnetic wiggler field. $\frac{k_w}{k_o} = 10$, $\frac{\omega_p}{\omega_o} = 0.2, 0.3, 0.4$, $\frac{\omega_{bw}}{\omega_o} = 0.4$

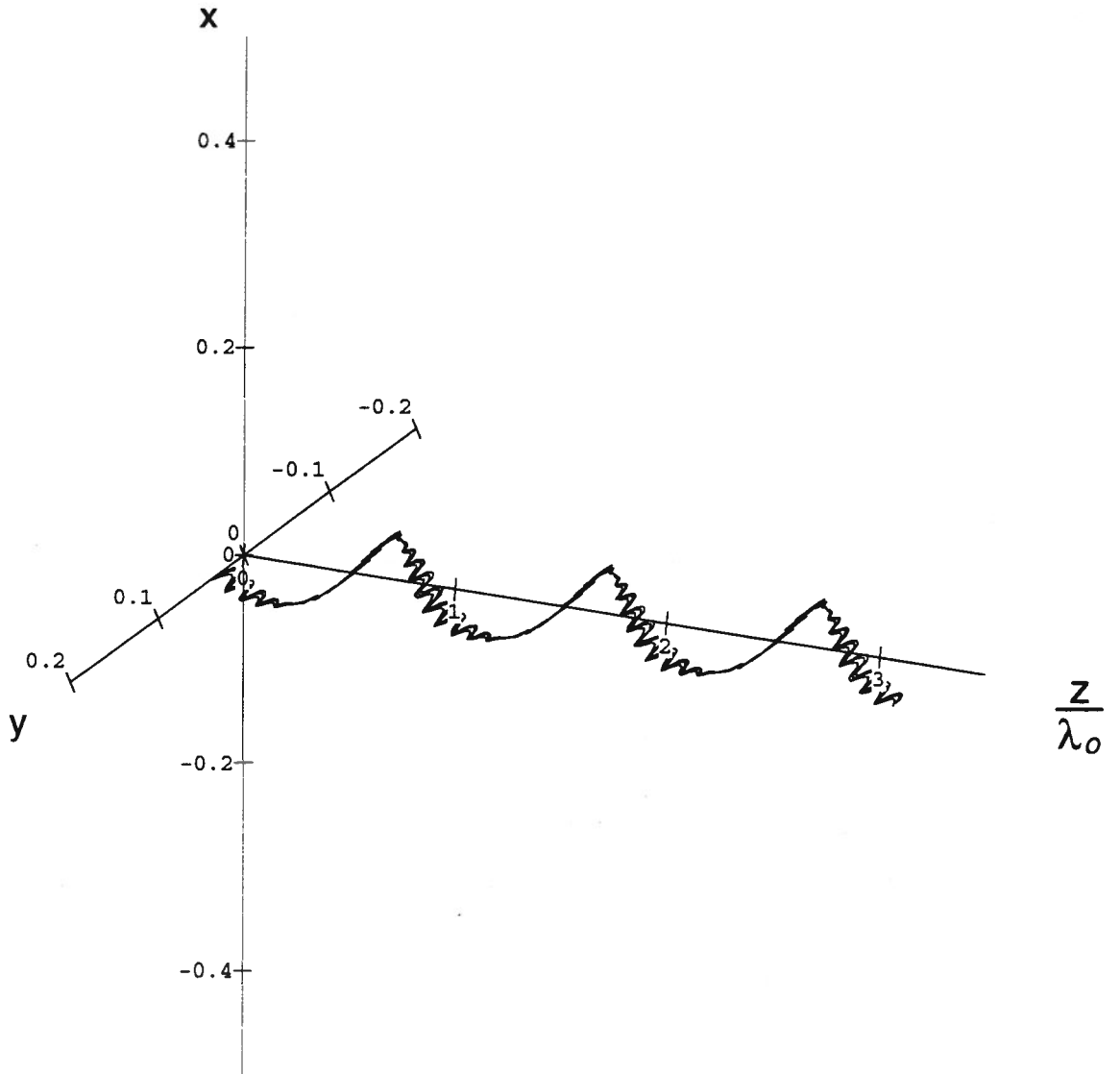

Figure 2.18 Magnetic wiggler field. $\frac{k_w}{k_0} = 10$, $\frac{\omega_p}{\omega_0} = 0.2$, $\frac{\omega_{bw}}{\omega_0} = 0.2, 0.3, 0.4$

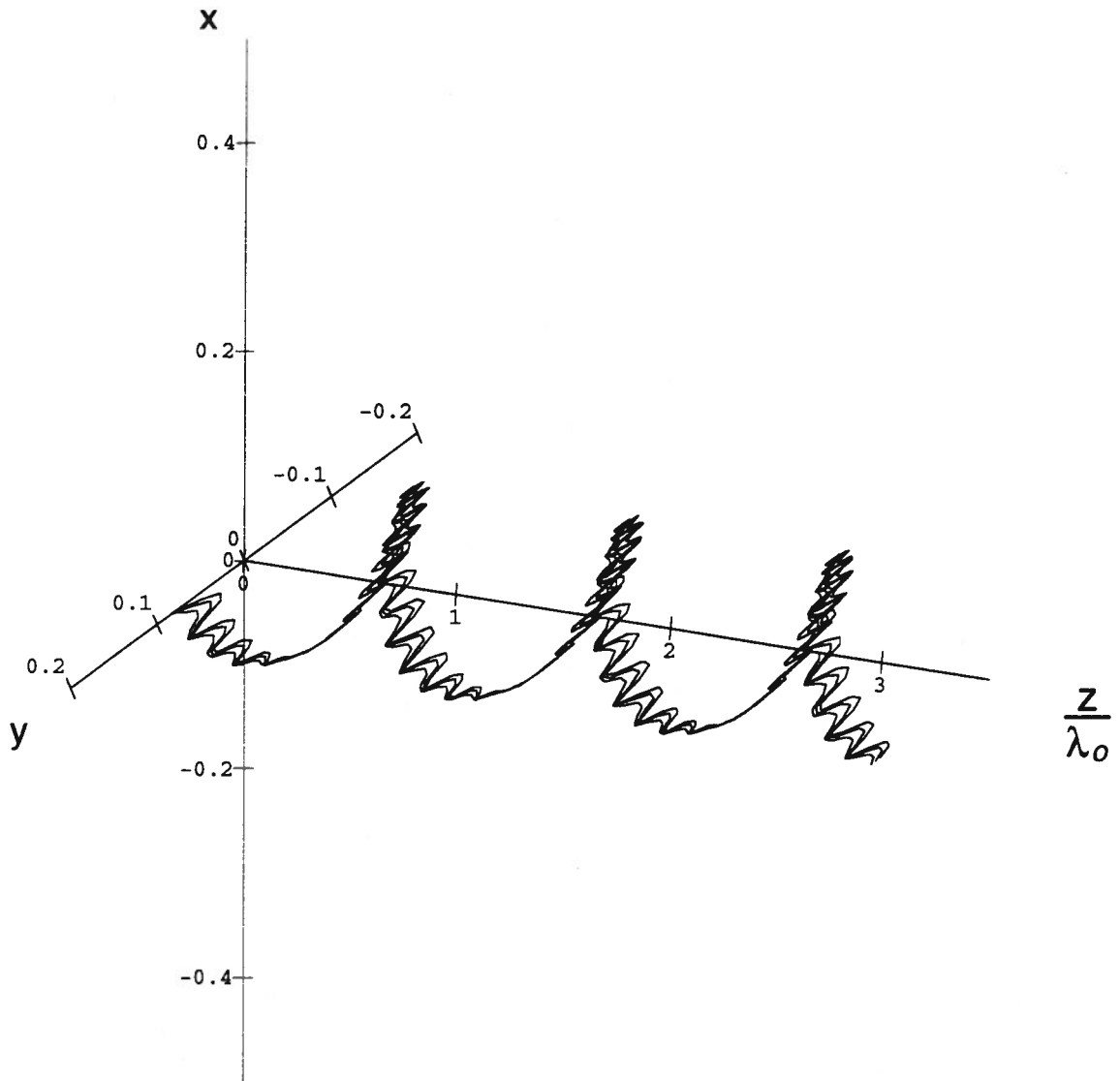

Figure 2.19 Magnetic wiggler field. $\frac{k_w}{k_o} = 10$, $\frac{\omega_p}{\omega_o} = 0.3$, $\frac{\omega_{bw}}{\omega_o} = 0.2, 0.3, 0.4$

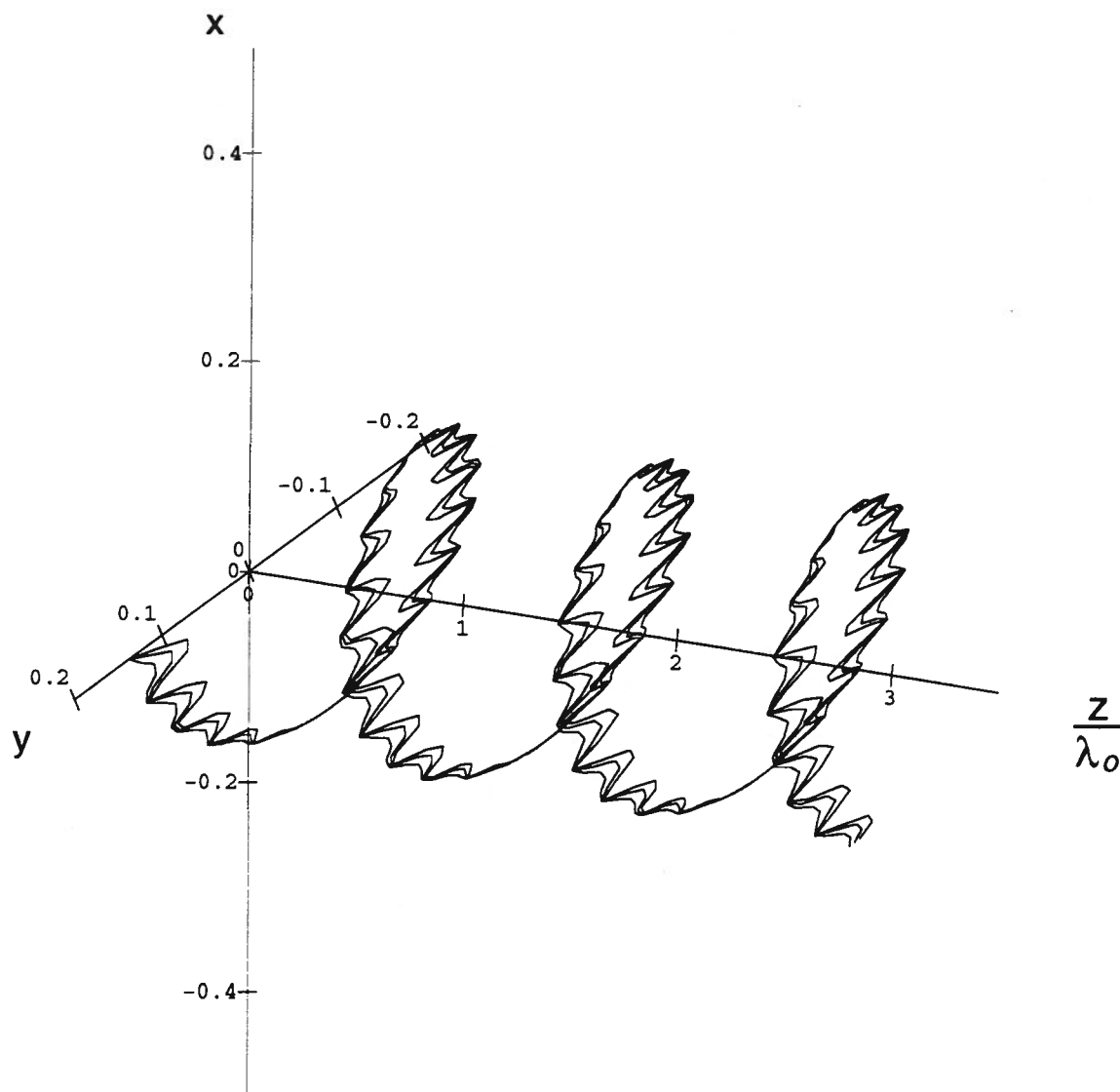

Figure 2.20 Magnetic wiggler field. $\frac{k_w}{k_o} = 10$, $\frac{\omega_p}{\omega_o} = 0.4$, $\frac{\omega_{bw}}{\omega_o} = 0.2, 0.3, 0.4$

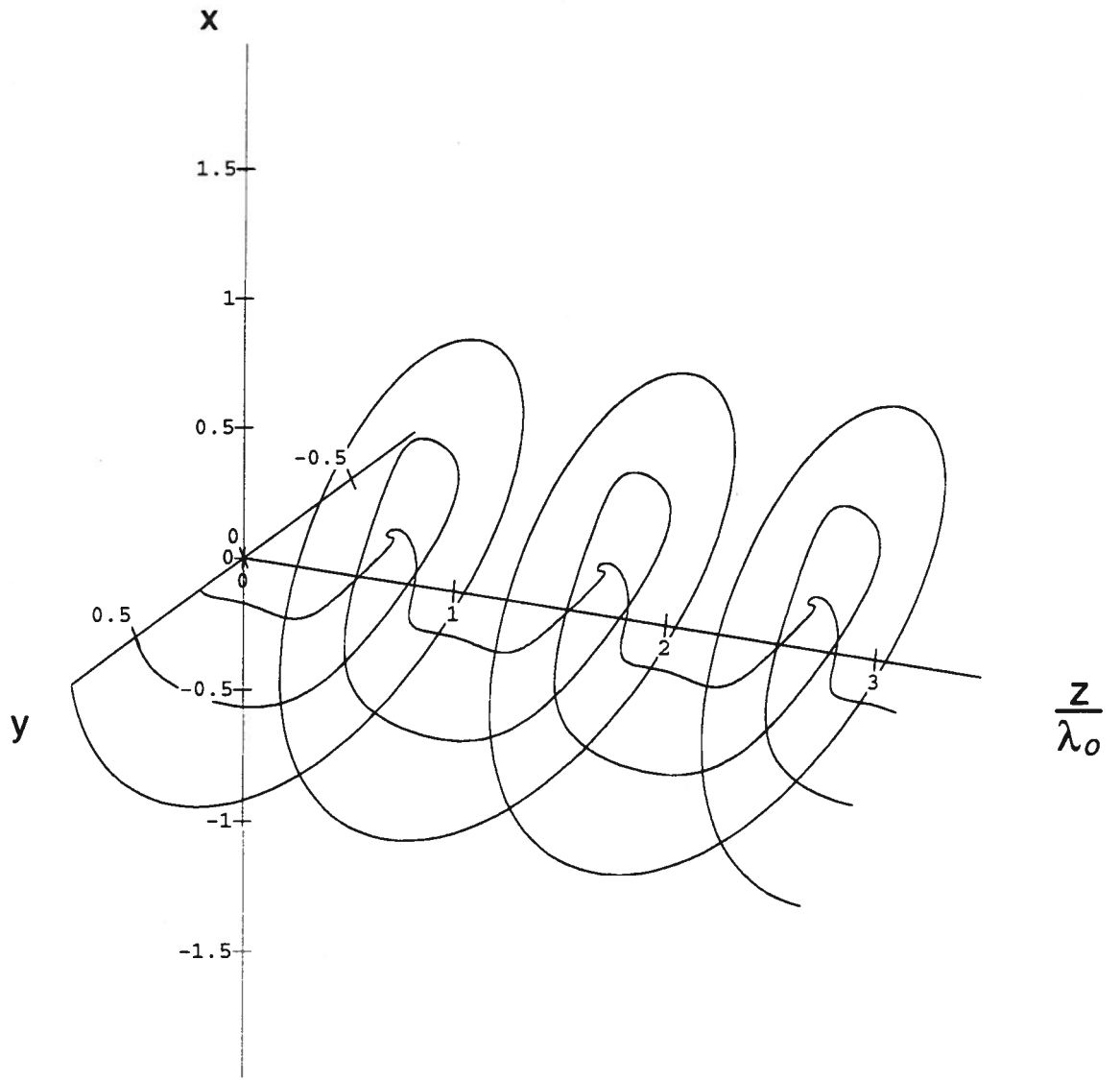

Figure 2.21 Magnetic wiggler field. $\frac{k_w}{k_0} = 1$, $\frac{\omega_p}{\omega_0} = 0.5, 1.0, 2.0$, $\frac{\omega_{bw}}{\omega_0} = 1.0$

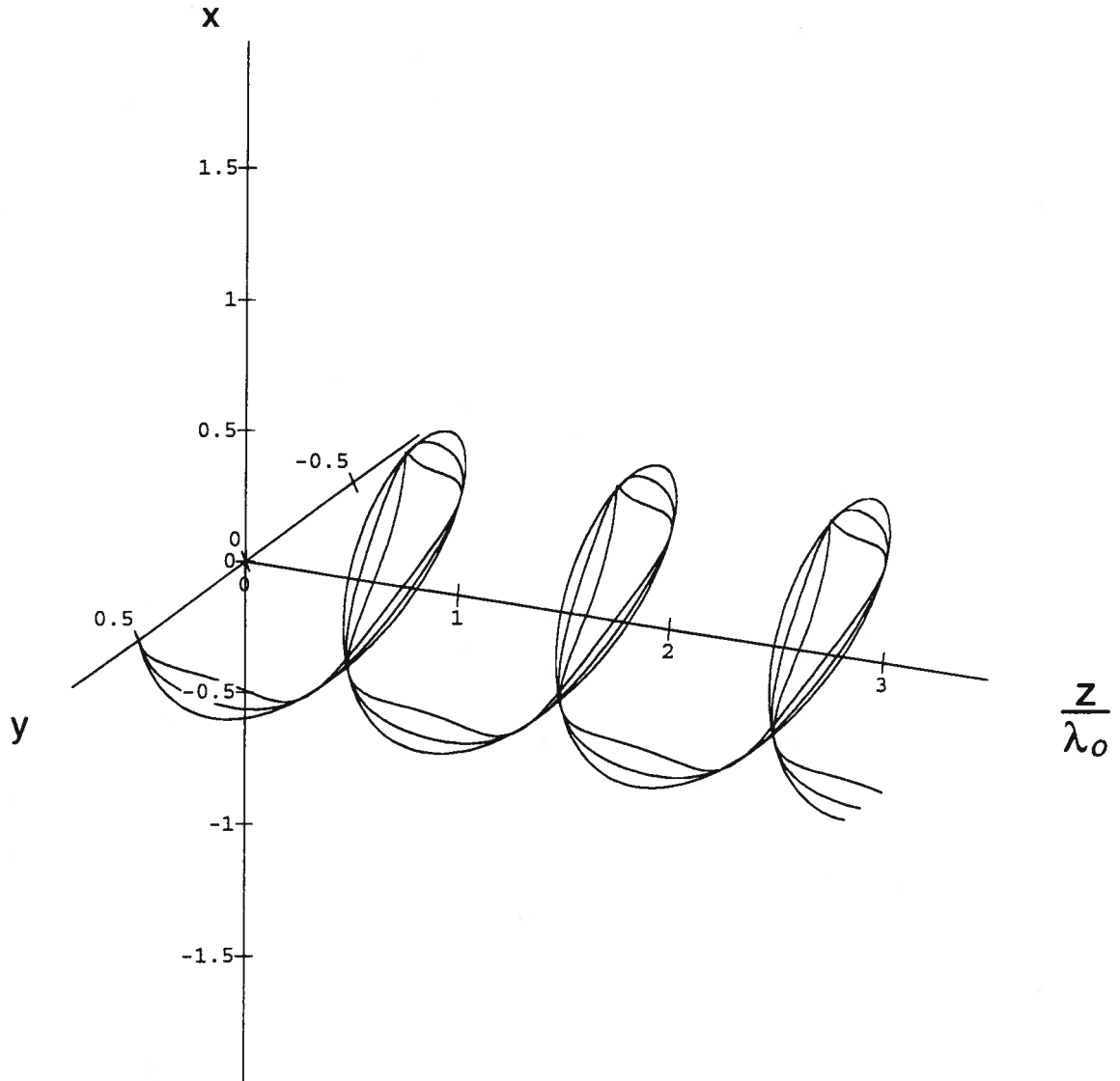

Figure 2.22 Magnetic wiggler field. $\frac{k_w}{k_o} = 1$, $\frac{\omega_p}{\omega_o} = 1$, $\frac{\omega_{bw}}{\omega_o} = 0, 1, 2$

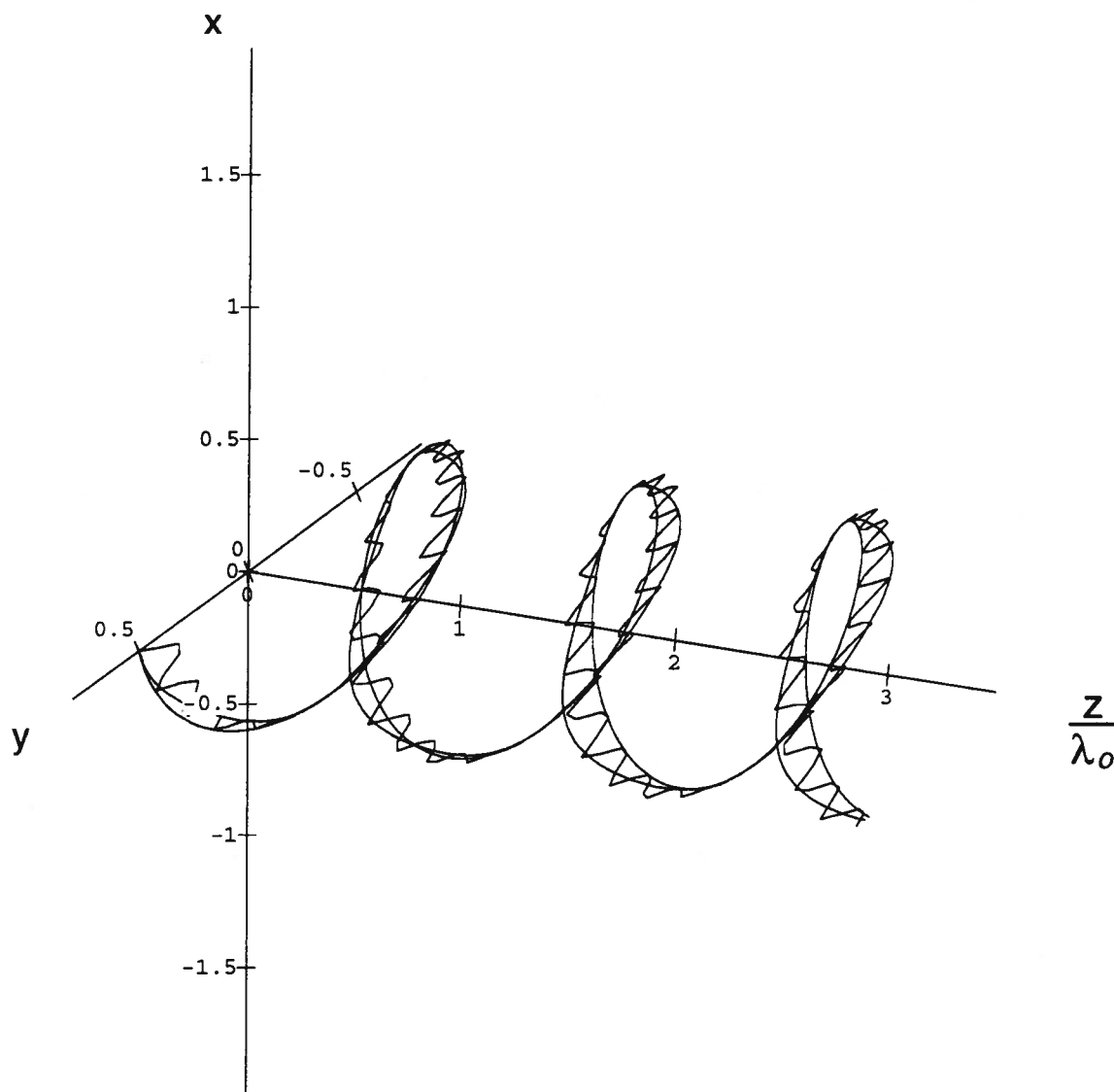

Figure 2.23 Magnetic wiggler field. $\frac{k_w}{k_o} = 0.1, 1, 10$, $\frac{\omega_p}{\omega_o} = 1.0$, $\frac{\omega_{bw}}{\omega_o} = 1.0$

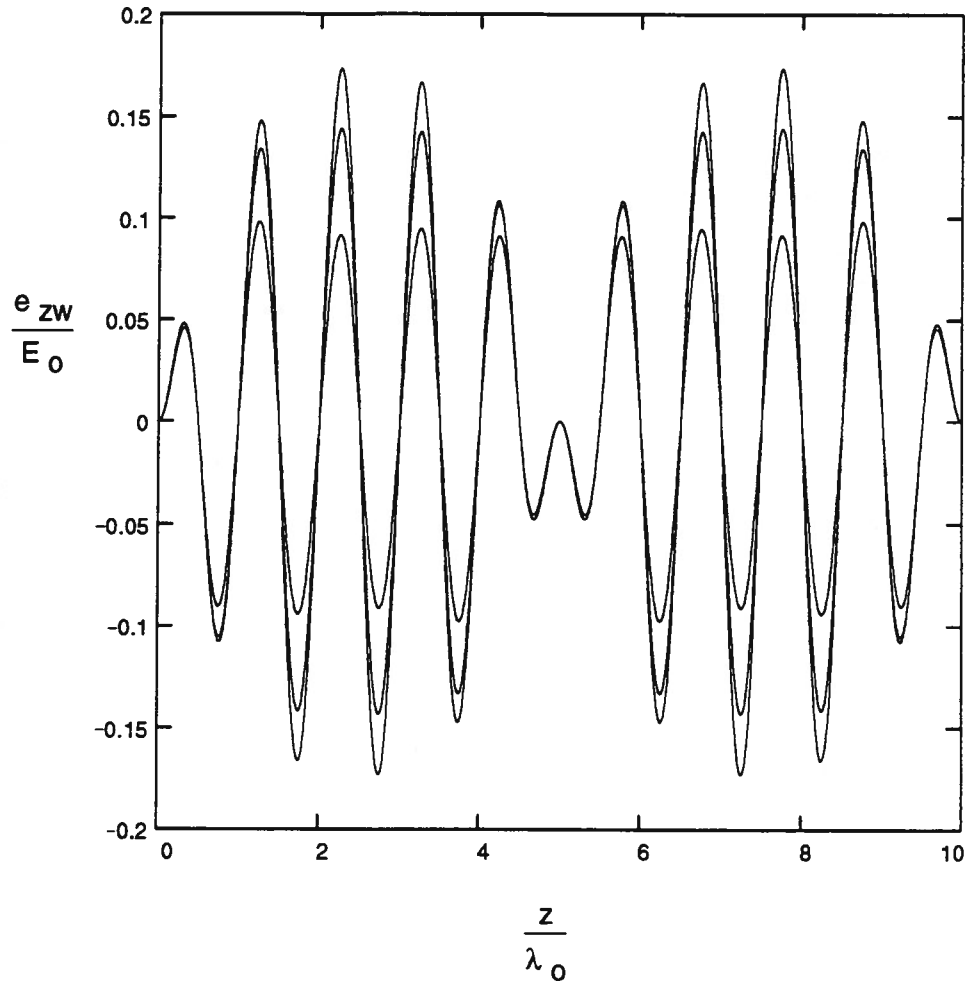

Figure 2.24 Electric wiggler field. $\frac{k_w}{k_0} = 0.1$, $\frac{\omega_p}{\omega_0} = 0.2, 0.3, 0.4$, $\frac{\omega_{bw}}{\omega_0} = 0.3$

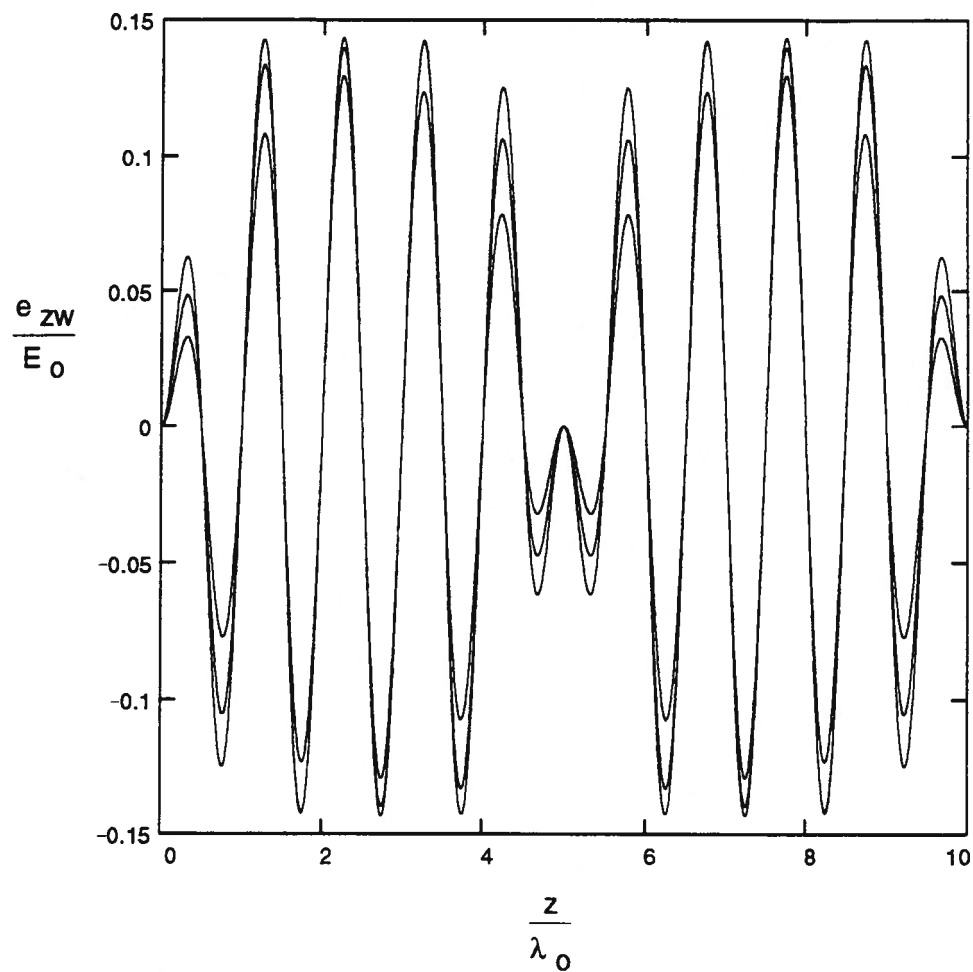

Figure 2.25 Electric wiggler field. $\frac{k_w}{k_o} = 0.1$, $\frac{\omega_p}{\omega_o} = 0.3$, $\frac{\omega_{bw}}{\omega_o} = 0.2, 0.3, 0.4$

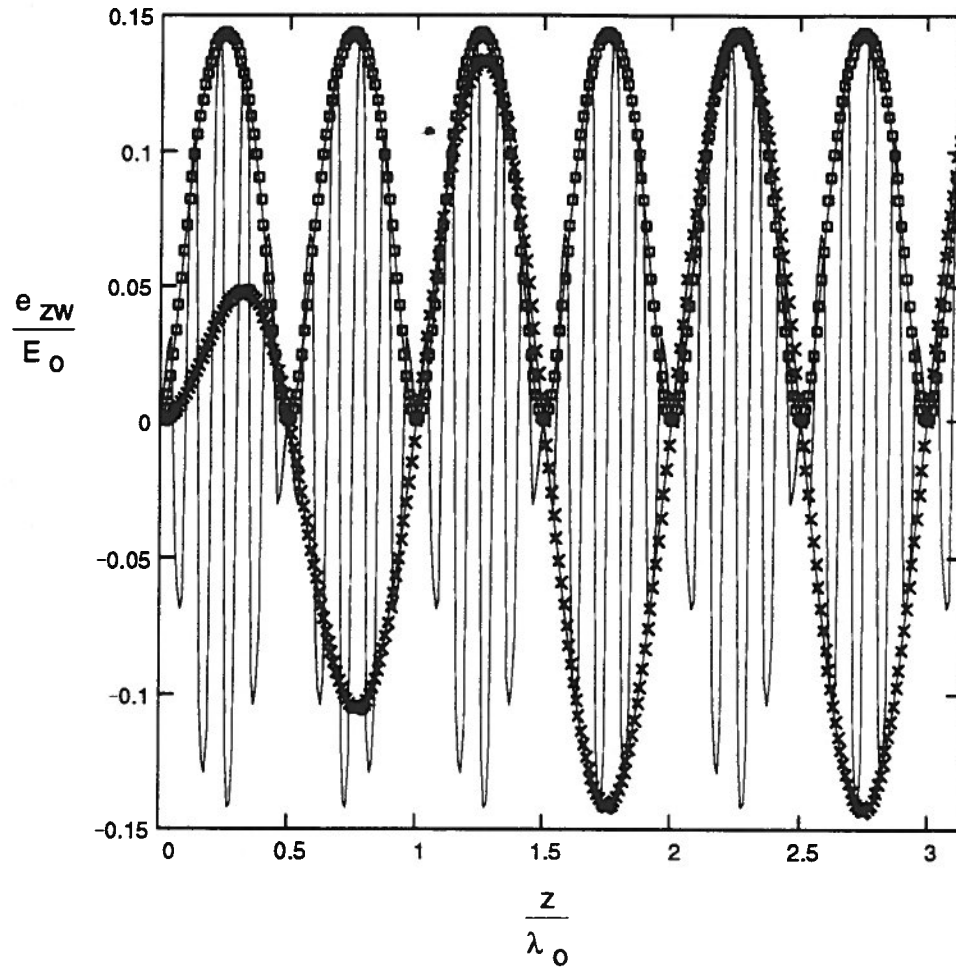

Figure 2.26 Electric wiggler field. $\frac{k_w}{k_o} = 0.1, 1.0, 10$, $\frac{\omega_p}{\omega_o} = 0.3$, $\frac{\omega_{bw}}{\omega_o} = 0.3$